

DOSAPACK MAX

Automatic powder reagent preparation equipment.



Compact and complete, the Dosapack Max dosing units are ideal for the automatic and continuous preparation, storage and injection of very different types of reagent.

APPLICATIONS:

Equipment designed to prepare solutions with a concentration of less than 200 g/l from granulated or powder product (grain size below 180 µm) in an automatic and continuous process.

The Dosapack Max equipment can be used to prepare the main chemical reagents:

- Reagents used in water treatment:
 - o Lime slurry
 - o Potassium permanganate
 - o Sodium metabisulphite
 - o Trisodium phosphate
 - o Etc.
- Other types of reagent for industrial applications.

MAIN FEATURES:

Designed as a compact unit, all of its parts are mounted on a skid of common carbon steel. The unit is supplied fully fitted so that all that remains is to install the unit on its foundations and make the connections to the tank supply and to the electrical cabinet.

It includes the following parts:

- Tank with water inlet line, overflow and drain
- Powder dispenser
- Agitator (mounted on the tank using a frameplate).
- Level control by means of an ultrasound level sensor.
- Protective and control electrical cabinet
- Common skid for the mounting of all parts.

This preparation module can be coupled up to dosing pumps or progressive cavity pumps fully installed on an attached, additional skid to form a single unit.



DESCRIPTION OF THE PARTS:

- **Tank:**

The tanks are made entirely of rotomoulding or shells of POLYETHYLENE (HDPE), the top and base of welded panels made of automatic or extruded thermoplastic, all of the welds being inspected using a high-frequency comb to detect pores or cracks in them.

Volumes available 130 l, 280 l, 500 l, 1000 l, 1500 l, 2000 l and 3000 l.

- **Water supply:**

The water inlet unit is a line of PVC piping formed by a flow adjustment valve, a pressure regulating valve, an NC solenoid valve and a float or variable section rotameter to allow for suitable adjustment of the solution water inlet flow

- **Powder dispenser**

The Powder product Dispenser is of the volumetric type with a

dosing screw. The flow is adjusted by continuous speed variation using a geared motor drive that is powered by a built-in frequency changer. There are several models with flow ranges to obtain the required concentration of the solution. It is also possible to install hoppers of various sizes (from 25 to 200 l) and a hopper vibration system and pneumatic membrane level switch are available as optional.

- **Agitator:**

The agitator can be of different types depending on the nature of the reagent, and generates sufficient pumping flow to encourage the effective dissolution of the solid phase.

- **Electrical cabinet**

The electrical cabinet is fitted with a microcontroller for the optimal functioning of the unit on receiving data from the ultrasound level sensor.

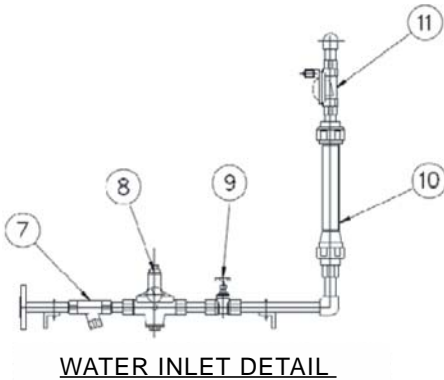

12	ELECTRICAL CABINET
11	SOLENOID VALVE
10	FLOW METER
9	GATE VALVE
8	PRESSURE REDUCTION VALVE WITH GAUGE
7	"Y" FILTER
6	LEVEL SWITCH
5	AGITATOR
4	AGITATOR SUPPORT BEDPLATE
3	75L HOPPER DP 31 TYP E DISPENSER
2	HIGH DENSITY POLYURETHANE TANK
1	SUPPORT BEDPLATE

Dimensions (*)

Volume	A	B	φ C	D	E	F
130 liters	1.650	1.200	φ 560	770	890	1.710
280 liters	1.650	1.200	φ 670	930	890	1.920
500 liters	1.650	1.200	φ 850	1.080	890	2.070
1000 liters	1.650	1.200	φ 1.012	1.460	890	2.450

(*) Models equipped with 75l hopper dp 31 type dispenser

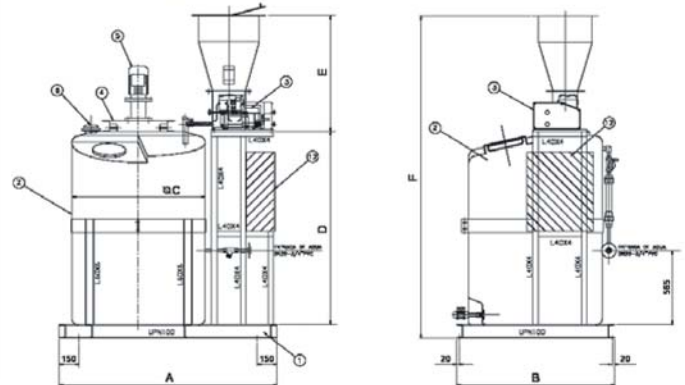

SDM
SISTEMAS DE DOSIFICACIÓN Y MEZCLA

C/ Embajadores, 100
28012 Madrid (Spain)
Telephone (+34) 91 353 18 13
Fax (+34) 91 345 97 07
info@sdm-sistemas.com

Visit our WEBSITE: www.sdm-sistemas.com