

Premium Magnetic-Drive Sealless Centrifugal Pumps

*Runs Dry for Hours
Guaranteed for Years*



FINISH THOMPSON INC.

Supreme Efficiency, Reliability and Performance

The DB Series

- Flooded Suction -

The DB Series magnetic drive pump is the new standard for hydraulic efficiency and corrosive fluid handling.

With design-aided magnetic flux and computational fluid dynamics technology, the DB Series packs all the high-pressure, fluid-handling punch you would expect from a Finish Thompson pump.

Born from painstaking, extensive R & D effort, the efficiency of the DB Series lowers energy consumption and operating costs over the long life cycle of the pump.

Constructed from Polypropylene or PVDF, the DB Series operates durably in the most corrosive of environments. It can even run dry without damage.

This rock solid embodiment of technological advancement is superior in precision, performance and reliability to other pumps on the market.

That's why we offer the industry's best five-year warranty. And why everyone else is undoubtedly heading back to the drawing board.



DB Series

The SP Series

- Self Priming -

Big on power, yet short on energy consumption, the SP Series from Finish Thompson is one of the most versatile – and economical – centrifugal pumps on the market.

Backed by an industry best five-year warranty, it is perfect for applications difficult for ordinary centrifugal pumps, such as pumping fluid from below grade, emptying tanker trucks or rail cars, transferring fluids from the top of tall bulk storage tanks to reduce the possibility of leaks from sidewall-mounted bulkhead fittings, overcoming piping systems that tend to have trapped or entrained air, or when optimum run-dry protection is needed.

The exclusive SP Series combines deep-lift capabilities (up to 25 feet/7.6 meters) and lightning-fast priming (18 feet/5.5 meters in 90 seconds) with the advantages of magnetic drive technology—ensuring ease of operation with no seal replacement, no leaks and the capability to run dry without damage.

Its innovative design and corrosion-resistant materials make the SP Series ideal for handling even the most difficult applications.



SP Series

DB / SP Series Technical Specifications

Features

- + Close-coupled design
- + Polypropylene or PVDF construction
- + Replaceable shaft
- + ISO 1940 G2.5 balancing
- + Mounts to NEMA and IEC motor frames
- + Mounts to motor without disassembly
- + Back pullout design
- + Five-year warranty
- + CE certified
- + ATEX available (DB only)

Capabilities

- + Up to 70% operating efficiency
- + High working pressure up to 90 psi
- + High specific gravity handling – over 1.8*
- + Maximum viscosity:
 - DB - 150 cP
 - SP - 50 cP
- + Maximum Temperature:
 - Polypropylene - 180° F (82° C)
 - PVDF - 220° F (104° C)

SP Series Specific Capabilities

- + SP retains fluid for re-priming when shut off without a check valve
- + SP lifts up to 25 feet (7.6 meters)**
- + SP primes up to 18 feet (5.5 meters) in 90 seconds***

* Specific gravity affects lift capability. Divide 25 feet (7.6 meters) by the specific gravity to determine maximum lift.

** Lift determined on fresh, cold water.

*** With maximum diameter impeller.

Industries & Applications

- + Chemical manufacturing
- + Metal plating/working
- + Wastewater treatment
- + Fume scrubbing
- + Mining
- + Paper mills
- + Printing
- + Pharmaceutical processing
- + Agriculture
- + OEM equipment supply
- + General pump applications

SP Series:

- + Sumps
- + Underground storage tanks
- + Rail and tanker cars
- + Over-the-wall applications
- + Tanks with an opening on top
- + Piping systems that tend to have trapped or entrained air

NOTE: SP Series is not recommended for pumping flammable liquids.

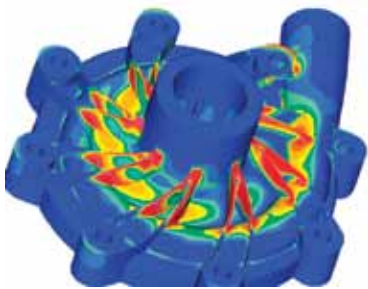

Engineered by computational fluid dynamics & Finite Element Analysis

DB & SP PREMIUM FEATURES

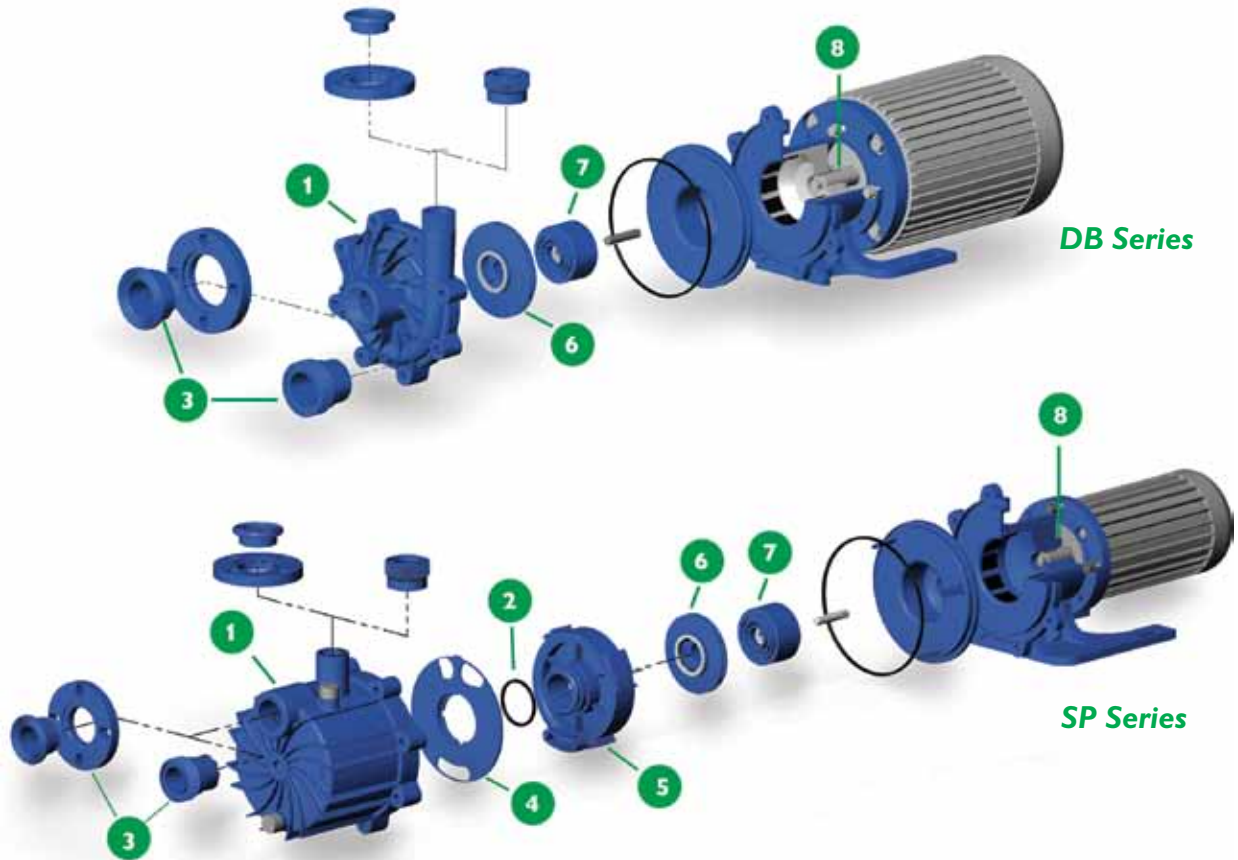

DB Series

SP Series

1. Thermoplastic Casing

Produces equivalent pump performance at both 60 Hz and 50 Hz operation. SP casing functions as a fluid reservoir featuring a molded-in “gooseneck” suction passage eliminating the need for internal check valves.

2. O-ring

On SP models, creates airtight seal between the inner volute and “gooseneck” suction passage. Helps maintain vacuum required for proper priming.

3. Multiple Connections

NPT or BSP threaded, raised-face adjustable flanges, or union connections

4. Separator Plate

Allows liquid to flow to the impeller and discharge the air/liquid mixture created during priming back into the fluid reservoir. (SP only)

5. Inner Volute

Allows air to be efficiently removed from the suction passages for fast priming. (SP only)

6. Impeller

Two-piece impeller design allows impeller to be changed without having to replace inner drive.

7. Run Dry System/Magnet Technology

The DB and SP can run dry for hours without damage when equipped with a chemical grade carbon bushing

Neodymium magnets are the most powerful and efficient magnets available. Inner magnets are completely encapsulated in unfilled polypropylene or PVDF to prevent corrosion of the magnets.

8. Easy Set Outer Drive

Measurement-free outer drive ensures optimum magnet alignment and easy motor installation.



SP PRINCIPLES OF SELF-PRIMING

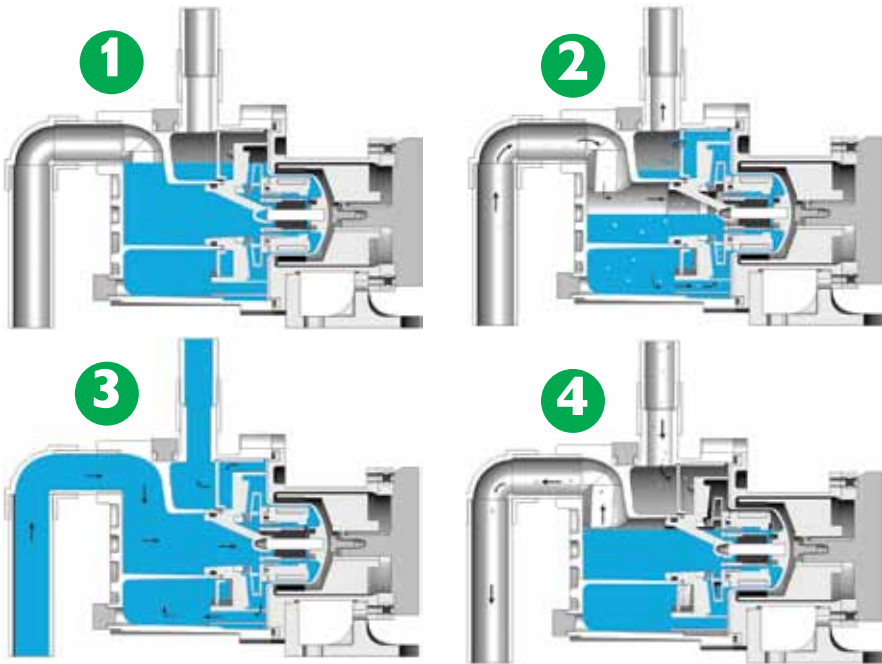

1 During pump installation, the priming housing is filled through the fill port.

2 As priming begins, air in the suction piping mixed with liquid in the priming chamber forms a vacuum in the inner volute. As they separate, the air rises out of the discharge piping while the liquid returns to the priming chamber.

3 The circulation process continues until liquid replaces all the air in the suction piping, beginning the pumping process.

4 When the pump is shut off, the priming chamber's gooseneck design ensures that enough liquid is retained for efficient re-priming.

SP APPLICATIONS

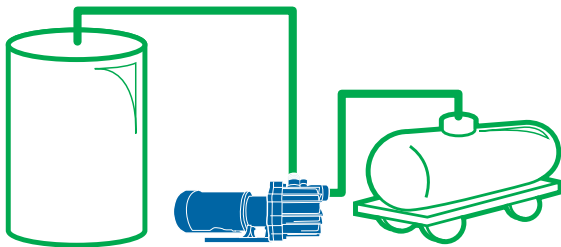

1 Transfer from top of rail cars or tanker trucks to bulk storage.

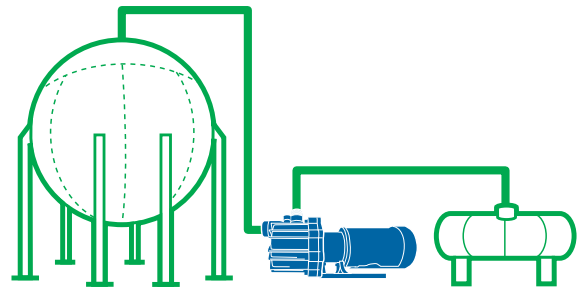

2 Transfer from bulk storage to process or day tanks.

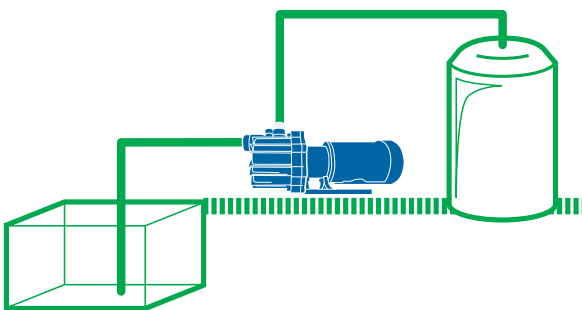

3 Pump from underground sumps or pits to treatment tanks.

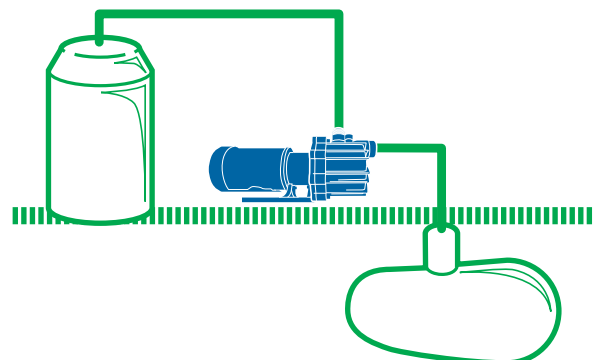

4 Pump from underground storage tanks to process or day tanks.

DB Series 3450/2900 rpm

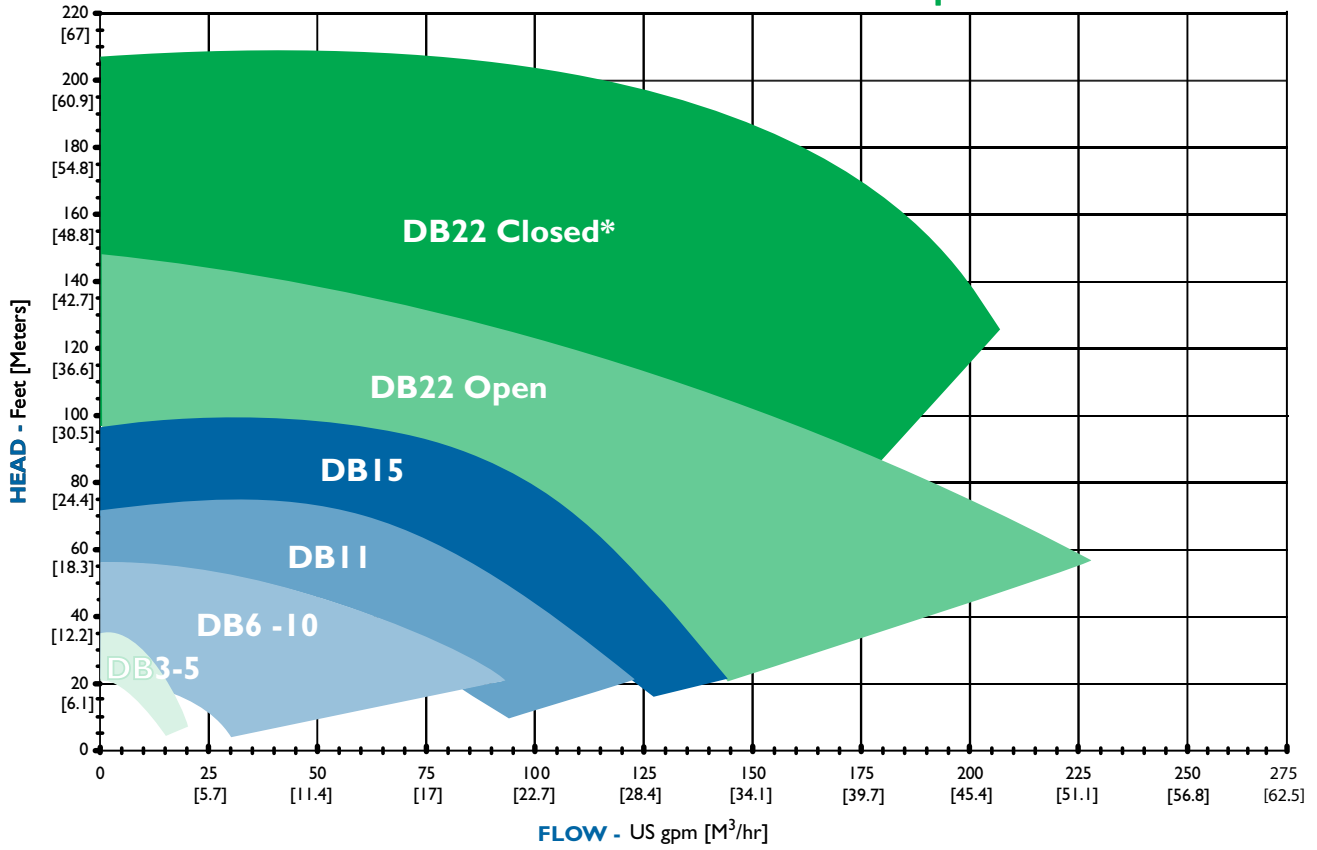

Note: Contact the factory or download the curve book for DB22 closed impeller performance at 2900 rpm.

SP Series 3450/2900 rpm

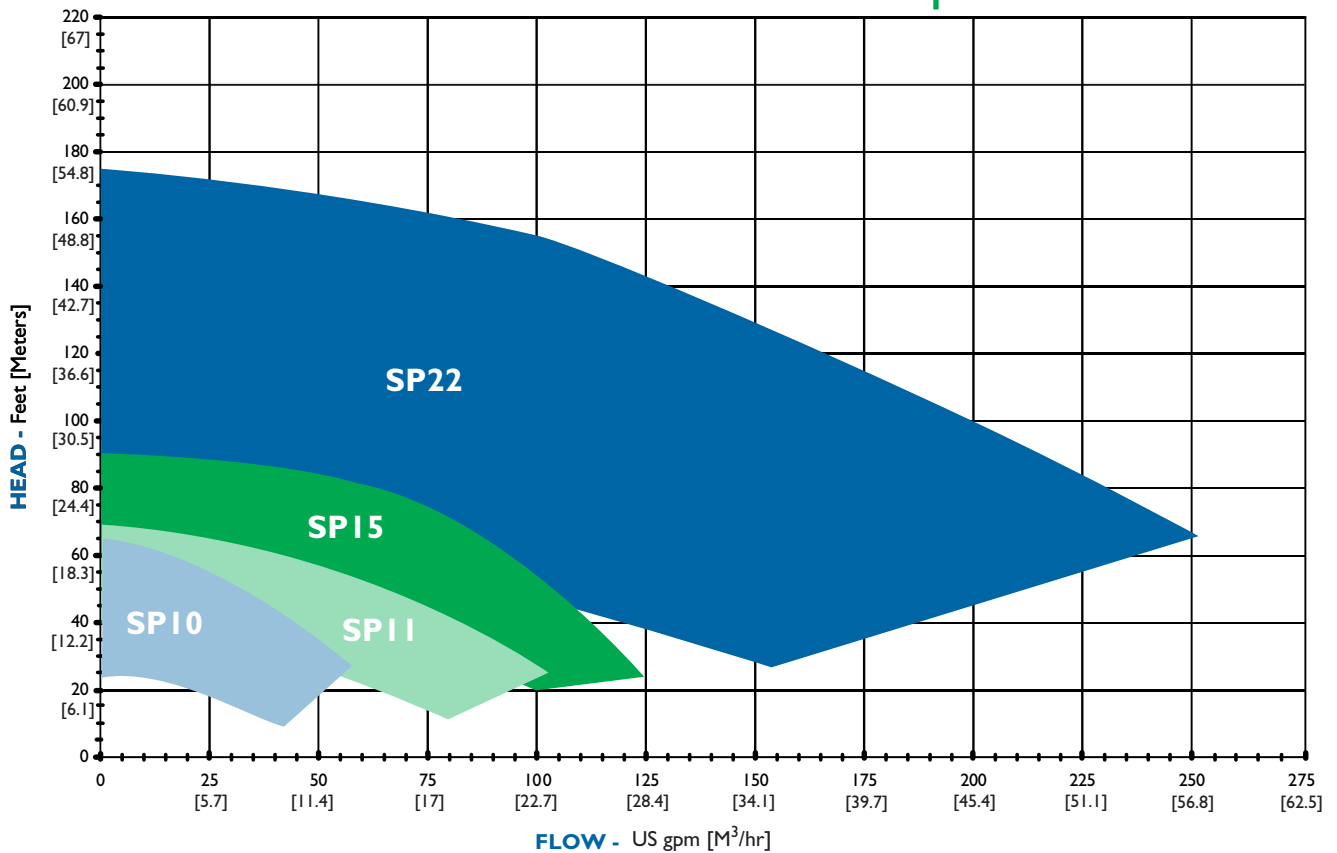

Note: SP curves based on flooded suction. Contact the factory or download the curve book for performance at various lifts.

DB / SP MATERIALS OF CONSTRUCTION

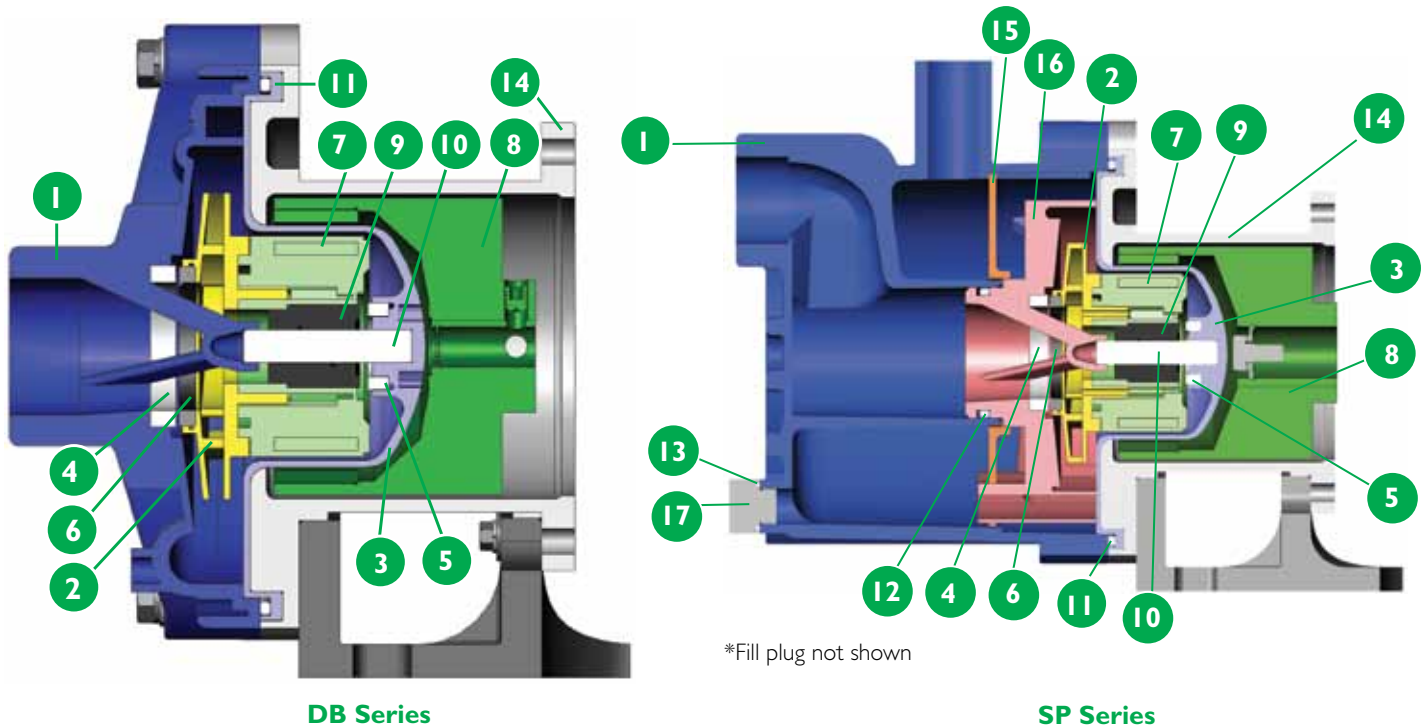

*Fill plug not shown

NOTE: The foot is offered only on the DB 11 & 15 and the SP 11 & 15 models

Item	Description	Polypropylene Models	PVDF Models
1, 2, 3, 15, 16	Housing, impeller; barrier; separator plate, inner volute	Glass-fiber reinforced polypropylene	Carbon-fiber reinforced PVDF
4	Housing thrust ring, inner volute thrust ring	High-purity alumina ceramic, silicon carbide	
5	Barrier thrust ring	High-purity alumina ceramic	
6	Impeller thrust ring	Molybdenum disulfide filled PTFE, silicon carbide	
7	Inner drive magnet	Neodymium iron boron magnets encapsulated in unfilled polypropylene	Neodymium iron boron magnets encapsulated in unfilled PVDF
8	Outer drive magnet	Nickel-plated neodymium iron boron magnets / steel	
9	Bushing	Carbon, PTFE, high purity alumina ceramic, silicon carbide	
10	Shaft	High purity alumina ceramic, Hastelloy C, silicon carbide	
11, 12, 13	O-ring	FKM, EPDM (Simriz®, Kalrez® - DB only)	
14	Motor adapter	Glass-fiber reinforced polypropylene and/or ductile iron	
17	Fill/drain plugs (SP only)	Polypropylene	PVDF

Kalrez® is a registered trademark of DuPont Performance Elastomers

Simriz® Perfluoroelastomer is a registered trademark of the Simrit® division of Freudenberg-NOK

Hastelloy® C is a registered trademark of Haynes International, Inc.



Finish Thompson Inc.

is a designer and manufacturer of premium pumps for safe and reliable industrial fluid handling.

All products are manufactured on site in Erie, Pennsylvania, U.S.A. and sold worldwide through an international network of stocking distributors.

Established in 1951 as a designer and builder of custom decorating equipment, Finish Thompson has evolved as a primary supplier of chemical transfer pumps for corrosive duty environments and as an industry leader in the design and engineering of magnetic drive centrifugal pumps.

Other great products from Finish Thompson....

ETFE-Lined Cast Ductile Iron Pumps



Drum / Barrel Pumps



Mechanical Sealed Pumps



VISIT FTI'S ONLINE PUMP SELECTORS:



www.finishthompson.com



FINISH THOMPSON INC.

921 Greengarden Road • Erie, PA 16501-1591 U.S.A.

Ph 814-455-4478 • Fax 814-455-8518

Email fti@finishthompson.com • www.finishthompson.com

FT10-1120A